



DC-DC 20WH2-30WH2系列



宽电压输入

隔离稳压正负双路/单路输出

DC/DC 模块电源

产品特点

- 宽电压输入2:1,4:1
- 双排直插 (DIP), 转接板兼导轨 (ZD)
- 宽工作温度范围: -40°C ~ +85°C
- 隔离电压1500VDC 0.5mA 1Minute
- 内部贴片化设计
- 金属外壳封装
- 符合RoHS指令
- 散热方式: 自然冷却
- 有良好的屏蔽抗干扰性能及电磁兼容性、防雷击、输出过流、短路保护、过热保护、自恢复等功能

产品概述

W(U)R(F)DXXSXX(ZD)-20WH2, W(U)R(F)DXXDXX(ZD)-20WH2, W(U)R(F)DXXSXX(ZD)-30WH2, W(U)R(F)DXXDXX(ZD)-30WH2 系列产品是我公司研发的最新产品, 本产品具备4.5 ~150VDC 的超宽输入电压. 同时具有效率高及低功耗的特点, 产品符合绿色环保要求, 金属外壳, 具有过流, 短路保护功能.

应用领域

铁路通讯, 显示屏, 监控设备, 石油化工, 工业控制, 远距离直流供电系统, 交换系统等通讯设备等.

WR(F)DXXSXX-20W/30WH2, WR(F)DXXDXX-20W/30WH2

型号	输入电压(V)	输出电压 (V±2%)	满载输出电流 (mA)	效率	隔离耐压 VDC	重量 (g) ±05	封装	认证
WRD05S05-20WH2	5VDC (4.5-9VDC)	5VDC	4000	≥83%	1500	25	DIP	CE RoHS
WRD05S12-20WH2		12VDC	1667	≥85%	1500	25	DIP	
WRD05S24-20WH2		24VDC	833	≥86%	1500	25	DIP	
WRD05D05-20WH2		±5VDC	±2000	≥83%	1500	25	DIP	
WRD05D12-20WH2		±12VDC	±833	≥85%	1500	25	DIP	
WRD05D24-20WH2		±24VDC	±416	≥83%	1500	25	DIP	
WRD05S05-30WH2		5VDC	6000	≥83%	1500	25	DIP	
WRD05S12-30WH2		12VDC	2500	≥85%	1500	25	DIP	
WRD05S24-30WH2		24VDC	1250	≥86%	1500	25	DIP	
WRD05D05-30WH2		±5VDC	±3000	≥83%	1500	25	DIP	

注: 本公司为客户定做任意输入输出的模块电源, 如有特殊需求请致电我公司处, 除另有规定外, 输入=Vi, 模块电源的特性应符合表1的规定, 且适用于全温范围(-40°C ≤ Tc ≤ 85°C)



WR(F)DXXSXX-20W/30WH2, WR(F)DXXDXX-20W/30WH2

型号	输入电压(V)	输出电压 (V±2%)	满载输出电流 (mA)	效率	隔离耐压 VDC	重量 (g) ±05	封装	认证
WRD05D12-30WH2	5VDC (4.5-9VDC)	±12VDC	±1250	≥85%	1500	25	DIP	CE RoHS
WRD05D24-30WH2		±24VDC	±625	≥83%	1500	25	DIP	
WRD12S05-20WH2	12VDC (9-18VDC)	5VDC	4000	≥83%	1500	25	DIP	
WRD12S12-20WH2		12VDC	1667	≥85%	1500	25	DIP	
WRD12S24-20WH2		24VDC	833	≥86%	1500	25	DIP	
WRD12D05-20WH2		±5VDC	±2000	≥83%	1500	25	DIP	
WRD12D12-20WH2		±12VDC	±833	≥85%	1500	25	DIP	
WRD12D24-20WH2		±24VDC	±417	≥83%	1500	25	DIP	
WRD12S05-30WH2		5VDC	6000	≥83%	1500	25	DIP	
WRD12S12-30WH2		12VDC	2500	≥85%	1500	25	DIP	
WRD12S24-30WH2		24VDC	1250	≥86%	1500	25	DIP	
WRD12D05-30WH2		±5VDC	±3000	≥83%	1500	25	DIP	CE RoHS
WRD12D12-30WH2	±12VDC	±1250	≥85%	1500	25	DIP		
WRD12D24-30WH2	±24VDC	±625	≥83%	1500	25	DIP		
WRD24S05-20WH2	24VDC (18-36VDC)	5VDC	4000	≥83%	1500	25	DIP	
WRD24S12-20WH2		12VDC	1667	≥85%	1500	25	DIP	
WRD24S24-20WH2		24VDC	833	≥86%	1500	25	DIP	
WRD24D05-20WH2		±5VDC	±2000	≥83%	1500	25	DIP	
WRD24D12-20WH2		±12VDC	±833	≥85%	1500	25	DIP	
WRD24D24-20WH2		±24VDC	±416	≥83%	1500	25	DIP	
WRD24S05-30WH2		5VDC	6000	≥83%	1500	25	DIP	
WRD24S12-30WH2		12VDC	2500	≥85%	1500	25	DIP	
WRD24S24-30WH2		24VDC	1250	≥86%	1500	25	DIP	
WRD24D05-30WH2		±5VDC	±3000	≥83%	1500	25	DIP	
WRD24D12-30WH2	±12VDC	±1250	≥85%	1500	25	DIP		
WRD24D24-30WH2	±24VDC	±625	≥83%	1500	25	DIP		

注:本公司为客户定做任意输入输出电压的模块电源,如有特殊需求请致电我公司处除另有规定外,输入=Vi, 模块电特性应符合上表的规定,且适用于全温范围(-40°C≤Tc≤85°C).



WR(F)DXXSXX-20W/30WH2, WR(F)DXXDXX-20W/30WH2

型号	输入电压 (V)	输出电压 (V±2%)	满载输出电流 (mA)	效率	隔离耐压 VDC	重量 (g) ±05	封装	认证
WRD48S05-20WH2	48VDC (36-72VDC)	5VDC	4000	≥83%	1500VDC	25	DIP	
WRD48S12-20WH2		12VDC	1667	≥85%	1500VDC	25	DIP	
WRD48S24-20WH2		24VDC	833	≥86%	1500VDC	25	DIP	
WRD48D05-20WH2		±5VDC	±2000	≥83%	1500VDC	25	DIP	
WRD48D12-20WH2		±12VDC	±833	≥85%	1500VDC	25	DIP	
WRD48D24-20WH2		±24VDC	±417	≥85%	1500VDC	25	DIP	
WRD48S05-30WH2		5VDC	6000	≥83%	1500VDC	25	DIP	
WRD48S12-30WH2		12VDC	2500	≥85%	1500VDC	25	DIP	
WRD48S24-30WH2		24VDC	1250	≥86%	1500VDC	25	DIP	
WRD48D05-30WH2		±5VDC	±3000	≥83%	1500VDC	25	DIP	
WRD24D12-30WH2		±12VDC	±1250	≥85%	1500VDC	25	DIP	
WRD24D24-30WH2		±24VDC	±625	≥83%	1500VDC	25	DIP	

注:本公司为客户定做任意输入输出电压的模块电源,如有特殊需求请致电我公司处除另有规定外,输入=Vi, 模块电特性应符合上表的规定,且适用于全温范围(-40°C≤Tc≤85°C).



WR(F)DXXSXX-20W/30WH2,WR(F)DXXDXX-20W/30WH2

型号	输入电压 (V)	输出电压 (V±2%)	满载输出电流 (mA)	效率	隔离耐压 VDC	重量 (g) ±05	封装	认证
WRD110S05-20WH2	110VDC (70-150VDC)	5VDC	4000	≥83%	1500VDC	25	DIP	CE RoHS
WRD110S12-20WH2		12VDC	1667	≥83%	1500VDC	25	DIP	
WRD110S24-20WH2		24VDC	833	≥85%	1500VDC	25	DIP	
WRD110D05-20WH2		±5VDC	±2000	≥83%	1500VDC	25	DIP	
WRD110D12-20WH2		±12VDC	±833	≥85%	1500VDC	25	DIP	
WRD110D24-20WH2		±24VDC	±416	≥83%	1500VDC	25	DIP	
WRD110S05-30WH2		5VDC	6000	≥83%	1500VDC	25	DIP	
WRD110S12-30WH2		12VDC	2500	≥85%	1500VDC	25	DIP	
WRD110S24-30WH2		24VDC	1250	≥86%	1500VDC	25	DIP	
WRD110D05-30WH2		±5VDC	±3000	≥83%	1500VDC	25	DIP	
WRD110D12-30WH2		±12VDC	±1250	≥85%	1500VDC	25	DIP	
WRD110D24-30WH2		±24VDC	±625	≥83%	1500VDC	25	DIP	

注:本公司为客户定做任意输入输出电压的模块电源,如有特殊需求请致电我公司处除另有规定外,输入=Vi, 模块电特性应符合上表的规定,且适用于全温范围(-40°C≤Tc≤85°C).



UR(F)DXXS(D)XX-20WH2/UR(F)DXXS(D)XX-30WH2

型号	输入电压 (V)	输出电压 (V±2%)	满载输出电流 (mA)	效率	隔离耐压 VDC	重量 (g) ±05	封装	认证	
URD12S05-20WH2	12VDC (9-36VDC)	5VDC	4000	≥80%	1500VDC	25	DIP	CE RoHS	
URD12S12-20WH2		12VDC	1667	≥85%	1500VDC	25	DIP		
URD12S24-20WH2		24VDC	833	≥85%	1500VDC	25	DIP		
URD12D05-20WH2		±5VDC	±2000	≥80%	1500VDC	25	DIP		
URD12D12-20WH2		±12VDC	±834	≥85%	1500VDC	25	DIP		
URD12D24-20WH2		±24VDC	±417	≥83%	1500VDC	25	DIP		
URD12S05-30WH2		24VDC (18-72VDC)	5VDC	6000	≥80%	1500VDC	25		DIP
URD12S12-30WH2			12VDC	2500	≥85%	1500VDC	25		DIP
URD12S24-30WH2			24VDC	1250	≥85%	1500VDC	25		DIP
URD12D05-30WH2			±5VDC	±3000	≥80%	1500VDC	25		DIP
URD12D12-30WH2			±12VDC	±1250	≥85%	1500VDC	25		DIP
URD12D24-30WH2			±24VDC	±625	≥83%	1500VDC	25		DIP
URD24S05-20WH2	24VDC (18-72VDC)		5VDC	4000	≥80%	1500VDC	25		DIP
URD24S12-20WH2			12VDC	1667	≥85%	1500VDC	25		DIP
URD24S24-20WH2			24VDC	833	≥85%	1500VDC	25		DIP
URD24D05-20WH2			±5VDC	±2000	≥80%	1500VDC	25		DIP
URD24D12-20WH2			±12VDC	±834	≥85%	1500VDC	25		DIP
URD24D24-20WH2			±24VDC	±417	≥83%	1500VDC	25		DIP
URD24S05-30WH2		24VDC (18-72VDC)	5VDC	6000	≥80%	1500VDC	25		DIP
URD24S12-30WH2			12VDC	2500	≥85%	1500VDC	25		DIP
URD24S24-30WH2			24VDC	1250	≥85%	1500VDC	25		DIP
URD24D05-30WH2			±5VDC	±3000	≥80%	1500VDC	25		DIP
URD24D12-30WH2			±12VDC	±1250	≥85%	1500VDC	25		DIP
URD24D24-30WH2			±24VDC	±625	≥83%	1500VDC	25		DIP

注:本公司为客户定做任意输入输出电压的模块电源,如有特殊需求请致电我公司处除另有规定外,输入=Vi, 模块电特性应符合上表的规定,且适用于全温范围(-40°C≤Tc≤85°C).



外形尺寸及引脚方式

- W(U)RDXXS(D)XX-20WH2双排直插 (DIP) 封装

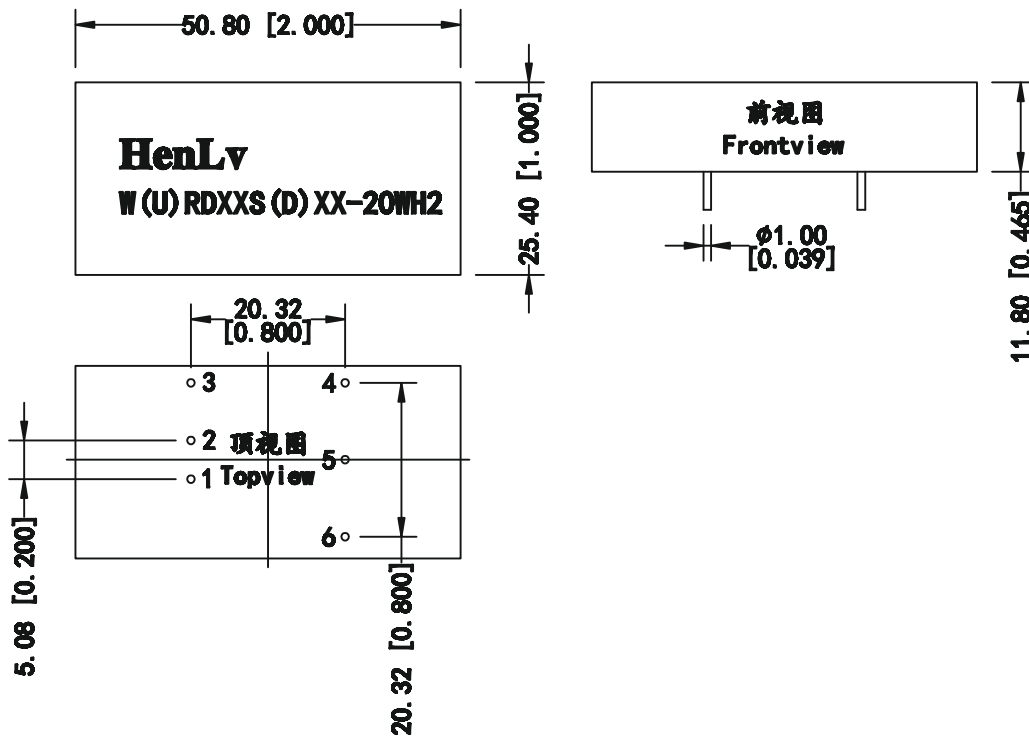

引脚	单路	双路
1	V _{in}	V _{in}
2	GND	GND
3	CNT	CNT
4	0V	-XXVDC
5	TRM	COM
6	+XXVDC	+XXVDC

尺寸单位: mm[inch]
 端子直径公差: ±0.10[±0.004]
 未标注公差: ±0.25[±0.010]

注:本公司为客户定做任意输入输出电压的模块电源,如有特殊需求请致电我公司处除另有规定外,输入=Vi, 模块电特性应符合上表的规定,且适用于全温范围(-40°C≤Tc≤85°C).



外形尺寸及引脚方式

- W(U)RDXXS(D)XX-30WH2 (DIP) 双排直插封装

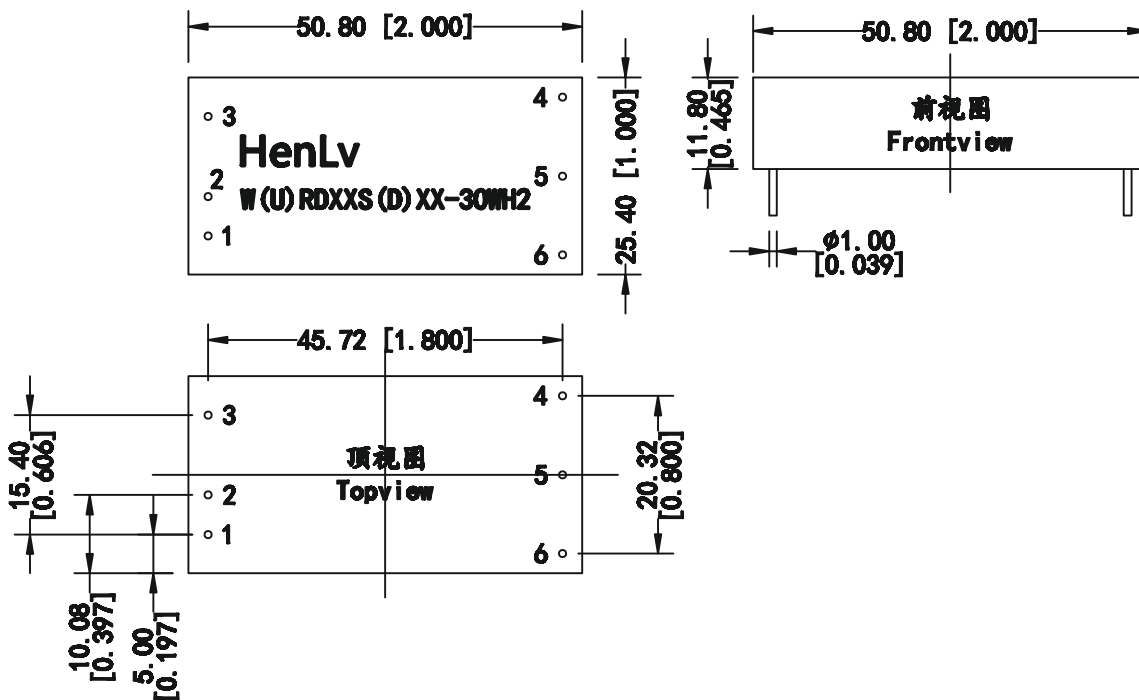

引脚	单路	双路
1	V _{in}	V _{in}
2	GND	GND
3	CNT	CNT
4	TRM	-XXVDC
5	0V	COM
6	+XXVDC	+XXVDC

尺寸单位: mm[inch]
 端子直径公差: ± 0.10 [± 0.004]
 未标注公差: ± 0.25 [± 0.010]

注:本公司为客户定做任意输入输出电压的模块电源,如有特殊需求请致电我公司处除另有规定外,输入=Vi, 模块电特性应符合上表的规定,且适用于全温范围(-40°C≤Tc≤85°C).



外形尺寸及引脚方式

W(U)R(F)DXXS(D)XXZD-20/30W系列 (ZD)

76.00*31.50(mm)

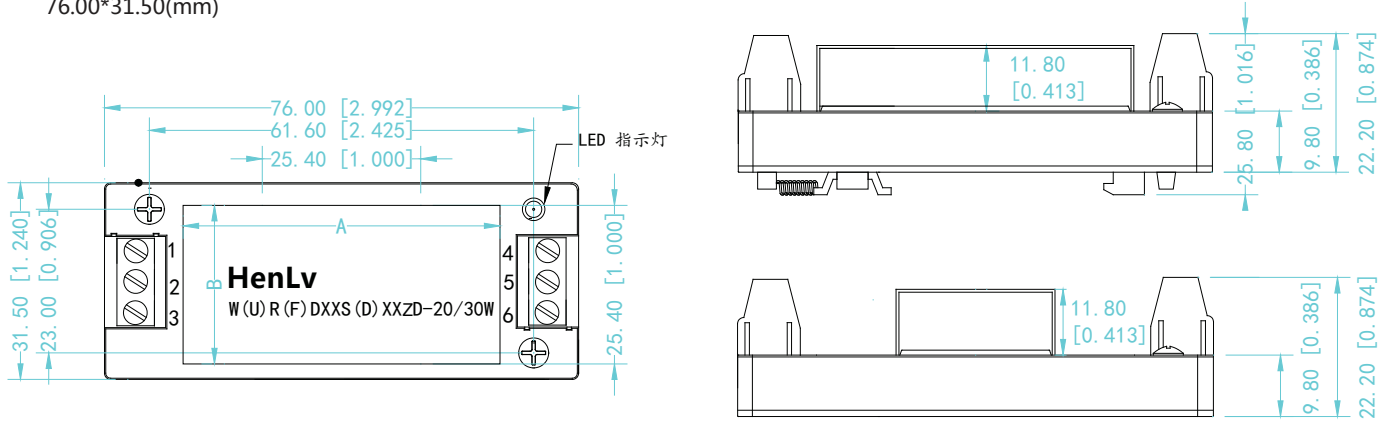

W(U)R(F)DXXS(D)XXZD-20W/30W

A=50.8

W(U)RDXXS(D)XXZD-20W/30W

B=25.4

尺寸单位: mm[inch]

端子直径公差: ± 0.10 [± 0.004]

未标注公差: ± 0.25 [± 0.010]

引脚A	单路	双路	引脚B	单路	双路
1	CNT	CNT	1	CNT	CNT
2	GND	GND	2	GND	GND
3	Vin	Vin	3	Vin	Vin
4	0V	-XXVDC	4	0V	-XXVDC
5	TRM	COM	5	TRM	COM
6	+XXVDC	+XXVDC	6	+XXVDC	+XXVDC

注:本公司为客户定做任意输入输出电压的模块电源,如有特殊需求请致电我公司处除另有规定外,输入=Vi, 模块电特性应符合上表的规定,且适用于全温范围(-40°C≤Tc≤85°C).



外形尺寸及引脚方式

W(U)RFDXXS(D)XX-20/30WH2 系列 (DIP)

25.40*25.40*11.80(mm)

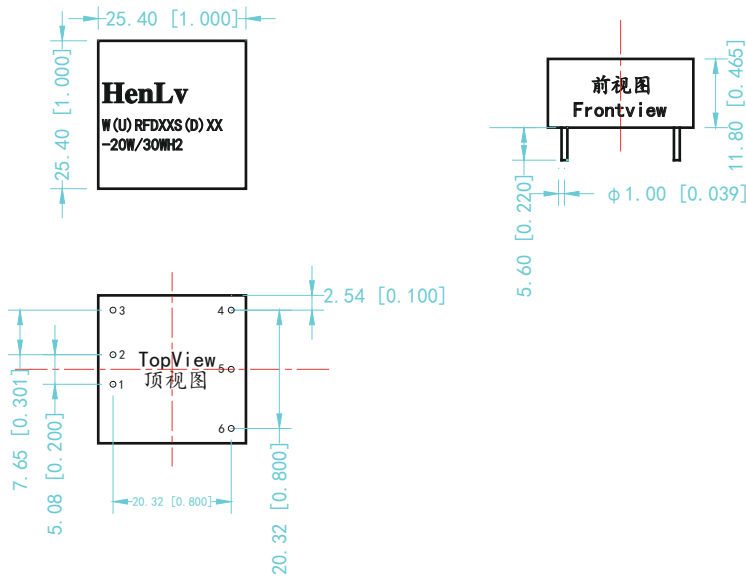

引脚	单路	双路
1	Vin	Vin
2	GND	GND
3	CNT	CNT
4	0V	-XXVDC
5	TRM	COM
6	+XXVDC	+XXVDC

尺寸单位: mm[inch]

端子直径公差: $\pm 0.10 [\pm 0.004]$

未标注公差: $\pm 0.25 [\pm 0.010]$

W(U)RDXXS(D)XX-30W 系列 (DIP)

50.80*50.80*12.70(mm)

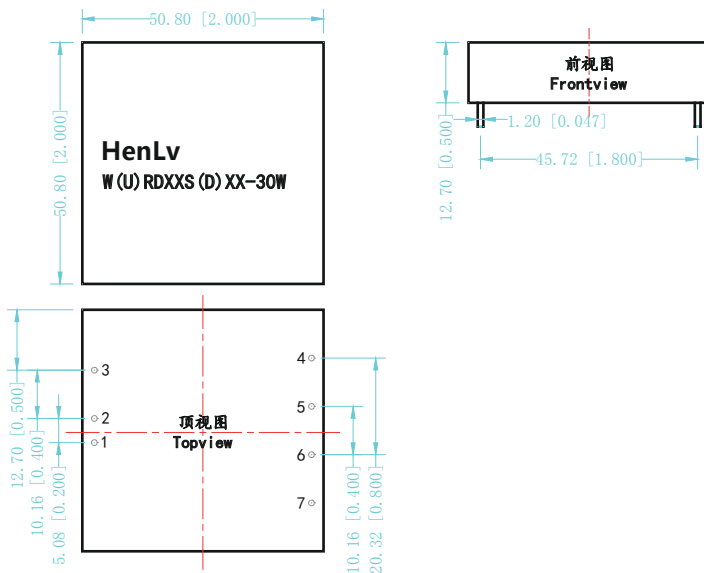

引脚	单路	双路
1	Vin	Vin
2	GND	GND
3	CNT	CNT
4	TRM	TRM
5	0V	-XXVDC
6	+XXVDC	COM
7	No Pin	+XXVDC

注:本公司为客户定做任意输入输出电压的模块电源,如有特殊需求请致电我公司处除另有规定外,输入=Vi, 模块电特性应符合上表的规定,且适用于全温范围(-40°C≤Tc≤85°C).



电特性

电特性

特性	符号	条 件 除另有规定外 $V_i, -40^{\circ}\text{C} \leq T_c \leq 85^{\circ}\text{C}$	极限值		单 位
			最小	最大	
输出电压	V_o	满载	$V_o - 2\%V_o$	$V_o + 2\%V_o$	V
最大输出电流	$I_{o\max}$	-	-	$\frac{P_o (\text{输出功率})}{U_o (\text{输出电压})}$	A
输出纹波电压	V_{p-p}	满载, $V_i, BW=20\text{MHz}$, 常温	$50 \pm 10\%$	$500 \pm 10\%$	mV
电压调整率	S_v	$V_{i\min}, V_i, V_{i\max}$, 满载	-	2.00	%
负载调整率	S_i	$V_i, I_o = (10\% \sim 100\%)I_{o\max}$	-	1.00	%
效率	η	V_i , 满载, 常温	68.00	-	%
绝缘电阻	RI	输入负、输出地之间加1500-3000VDC 常温, $t \geq 3\text{S}$	50	-	MΩ
过流保护电流值	FR	输出电流满载时	1.05倍	1.6倍	A
电磁兼容	磁场敏感度试验		GB-4943		
	静电放电敏感度试验		GB-4943		
	辐射敏感度试验		GB-4943		
	传导敏感度试验		GB-4943		
温漂	0.02%/°C				
频率	50K HZ~400K HZ (MAX)				
湿度	90% (max)				
漏电流	无				
MTBF	>500,000小时				



温度曲线图、误差包络曲线图

典型效率曲线

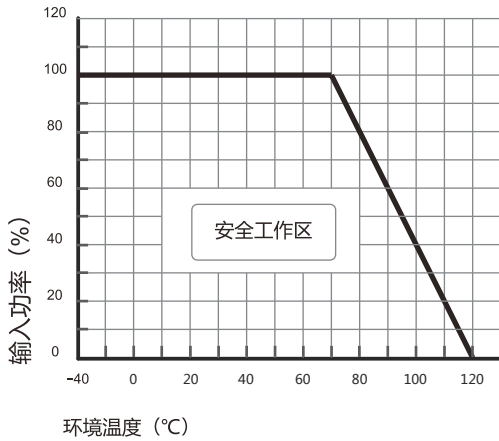

温度曲线图

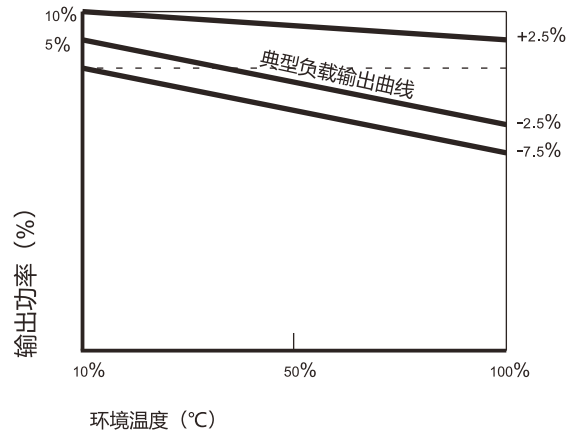

误差包络曲线图

典型效率曲线

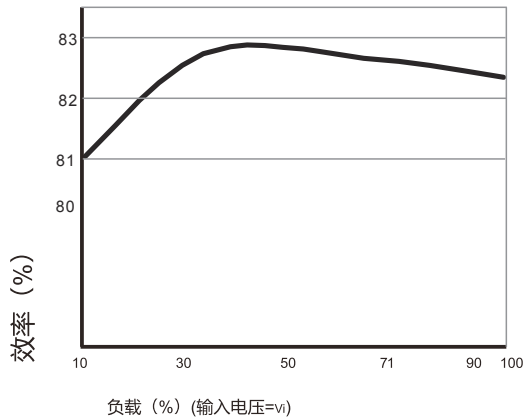

效率/负载曲线图

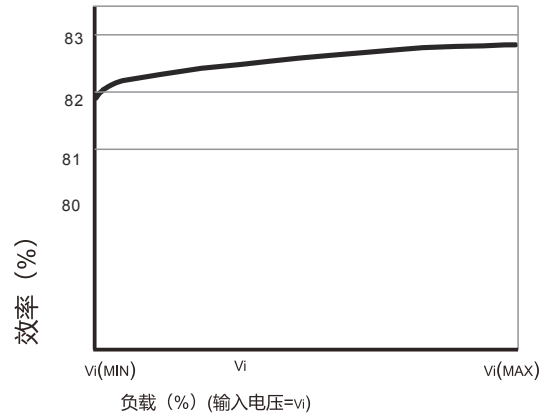

效率/输入电压曲线图

典型应用

推荐电路

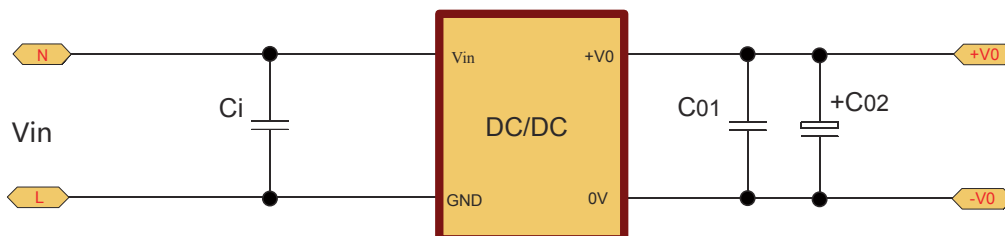



典型应用

• 推荐测试

滤波：在一些对噪声和纹波敏感的电路中，可在DC/DC输入端和输出端外接滤波电容，降低纹波对系统的影响，但滤波电容的取值要适当，若电容太大，很可能造成启动问题，对于每一路输出，在确保安全可靠工作的条件下，其滤波电容的最大容值可以参考外接电容表，为了获得非常低的纹波，可在DC/DC转换器输入输出端接一个“LC”滤波网络，这样滤波的效果会更好，同时应注意到电感值的大小及“LC”滤波网络其自身的频率应于DC/DC模块电源的频率错开，避免相互干扰。对于每一路输出，在确保安全可靠的工作条件下，建议其容性负载值详见（表1）

推荐输出容性负载值表（表1）

单路Vout	Cout	双路Vout	Cout
5~12VDC	22~68uF	±5~±12VDC	4.7~22uF
24~48VDC	10~47uF	±24~±48VDC	4.7~10uF

说明事项

• 包装

本系列模块采用防震防静电泡沫包装。

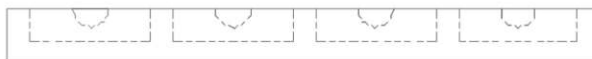
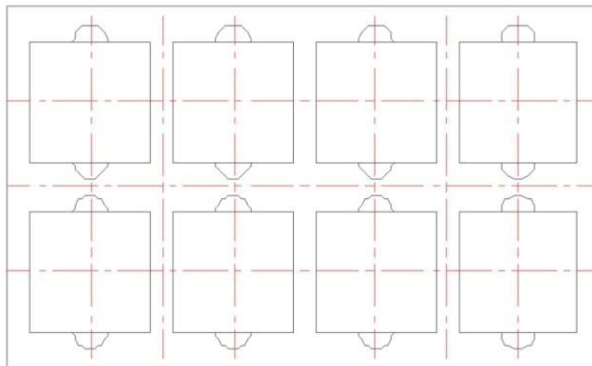

• 运输

装有模块的包装允许用任何运输工具运输，运输中应避免雨雪的直接淋袭和机械损伤。

• 贮存

模块应贮存在环境温度为-40度~125度，相对湿度10%~90%，周围环境无酸性、碱性及其它有害的气体的库房中。

以上均为本手册所列产品系列之性能指标，非标准型号产品的某些指标会超出上述要求，如此手册出现与产品规格文件不一致的情况，请以规格文件为准，有特殊需求可直接与我公司联系。